

IX81 dimensions

(unit: mm)

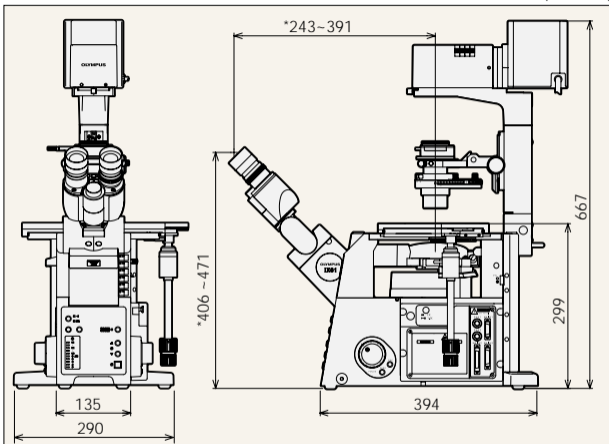

Weight: 26.0kg Power consumption: 350VA

* Lengths with an asterisk (*) vary according to interpupillary distance.

IX2-UCB dimensions

(unit: mm)

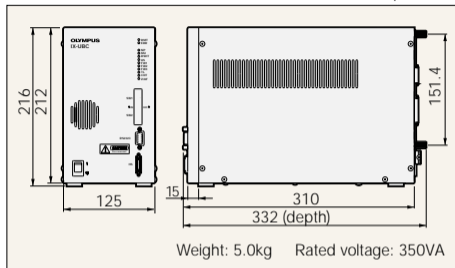

Weight: 5.0kg Rated voltage: 350VA

U-HSTR2 dimensions

(unit: mm)

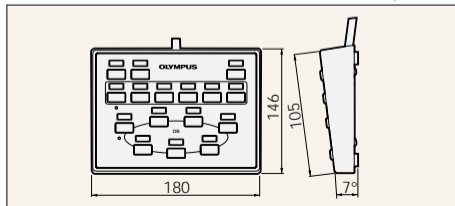

U-FH dimensions

(unit: mm)

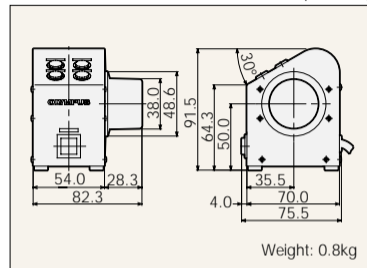

Weight: 0.8kg